

Nice Moby5000

For swing gates



24V

For swing gates with leaves up to 5 m.

Electromechanical gear motor irreversible, 24 Vdc, with magnetic encoder, mechanical stop in opening, surface mounted (**MB5024**).

Reliability and noiseless operation: fewer components and patented layout of the internal components.

Easy installation and maintenance with the waterproof, quick connector and incorporated condenser.

Quick, easy adjustment of the limit switches.

Bronze volute to guarantee safe closing.

Recommended control units:

Mindy A824/110

24 Vdc version with magnetic encoder, perfect for intensive use

- easy programming by pressing a single button
- clutch with anti-crush safety feature
- automatic memorization of limit switches in opening and closing with self-learning function
- pause time programming; partial opening; slowdown during opening and closing
- the system will operate during a blackout by means of rechargeable batteries



Utilisation limits

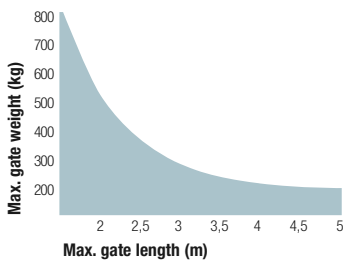

The shape, the height of the gate and the weather conditions can considerably reduce the values shown in the graph to the side.

Technical specifications		MB5024
Power	(Vdc)	24
Current absorbed	(line) (A)	5
Power absorbed	(W)	120
Protection level	(IP)	44
Speed	(m/s)	0.016
Travel	(mm)	480
Max thrust	(N)	2000
Working temp.	(°C Min/Max)	-20 ÷ +50
Work cycle	(%)	80
Dimensions	(mm)	953x110x110
Weight	(kg)	7

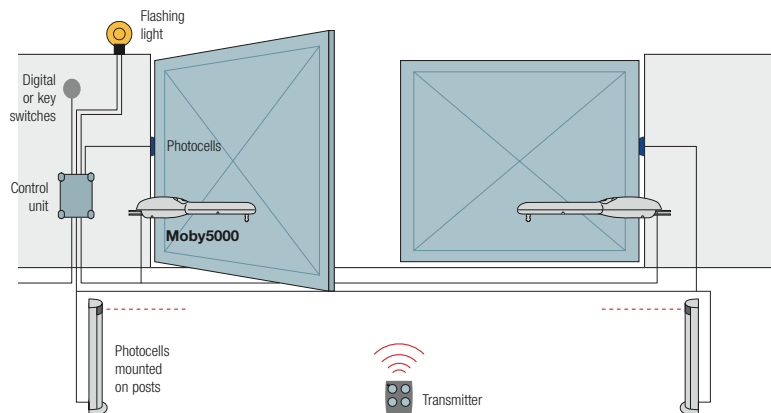



For swing gates with leaves up to 5 m.

Electromechanical gear motor, surface mounted.
Also available in 24 Vdc version, with magnetic encoder.
Ideal for residential and industrial use.

New third generation models:

quality and durability thanks to the housing, made up of two tough aluminium shells with polyester paint finish; more resistant to atmospheric agents.

Internal moving parts completely in steel, light alloys and technopolymers.

Reliable and silent:

patented layout of internal parts.

Lead nut in bronze

for strength and silent operation.

Generously sized and practical connection compartment:

rapid and easy access from above to internal parts located in the upper section of the motor.

Simple installation and maintenance,

with built-in capacitor.

Total interchangeability

with the series Moby: identical positions and fixing brackets.

TO5024I ideal for intensive work load, thanks to the torque of 2200 Nm, can work on continuous duty on large sized gates.

Recommended control units:

Mindy A3, A3F, A6, A6F, A60, A700F; for TO5024 and TO5024I Moonclever MC824H.

24 Vdc version

with magnetic encoder. Perfect for intensive use, compatible with the control unit Moonclever MC824H, equipped with BlueBUS, and provision for operation with the systems Solemyo and Opera:

- simple programming, by means of a single key;
- self-learning of opening and closing limit positions;
- automatic fault diagnostics;
- programming of pause time;
- pedestrian pass door;
- deceleration on opening and closing;
- obstacle detection with dual technology;
- operation in event of power failure by means of optional rechargeable batteries (PS324);
- provision for connection of latest generation resistive sensitive edges.

Technical specifications

Code	TO5024	TO5024I	TO5015	TO5016	TO5605
Electrical data					
Power supply (Vac 50 Hz)	-	-	230		
Power supply (Vdc)	24	-	-		
Absorption (A)	5	-	1.5	-	1.3
Power (W)	120	-	340	-	300
Built-in capacitor (µF)	-	-	7		
Performance data					
Speed (m/s)	0.016	-	0.013*		0.016
Force (N)	1800	2200	1800		
Work cycle (cycles/hour)	95*	75**	54		50
Dimensional and general data					
Protection level (IP)	44				
Working temp. (°C Min/Max)	-20 ÷ +50				
Dimensions (mm)	965x115x105 h				
Weight (kg)	7				

* With optimal installation.

** The reduction in number of manoeuvres with respect to the version TO5024 depends solely on the lower manoeuvre speed.

Installation diagram

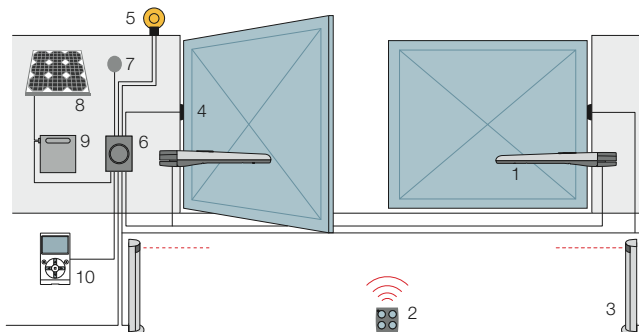

1. Toona
 2. Transmitter
 3. Photocells mounted on posts
 4. Photocells
 5. Flashing light
 6. Control unit
 7. Digital or key switches
 8. SYP* solar panel
 9. PSY24* battery box
 10. O-View* multifunction display.
- *Optional connection to Solemyo and Opera systems.

Utilisation limits

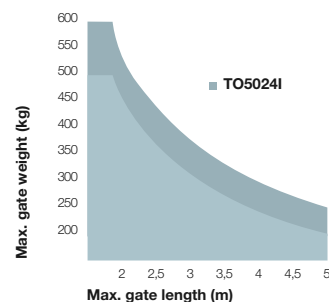

The shape, the height of the gate and the weather conditions can considerably reduce the values shown in the graph to the side. Use in windy areas 230 Vac models.

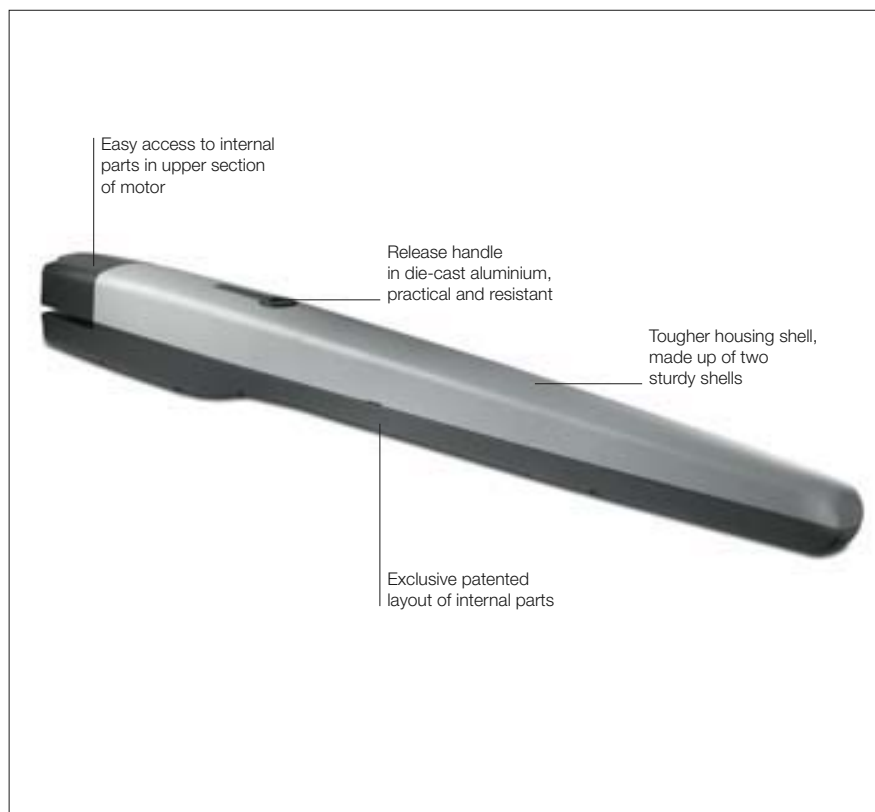

For swing gates with leaves up to 7 m.

Electromechanical gear motor, surface mounted, powered at 24 Vdc, with magnetic encoder. Ideal for industrial installations, designed for intensive use.

Compatible for operation with Solemyo and Opera systems.

New third generation models: quality and durability thanks to the housing, made up of two tough aluminium shells with polyester paint finish; more resistant to atmospheric agents.

Internal moving parts completely in steel, light alloys and technopolymers.

Reliable and silent: patented layout of internal parts.

Lead nut in bronze for strength and silent operation.

Generously sized and practical connection compartment: rapid and easy access from above to internal parts located in the upper section of the motor.

Control unit Moonclever MC824H, with BlueBUS technology:

- simple programming, by means of a single key;
- self-learning of opening and closing limit positions;
- automatic fault diagnostics;
- programming of pause time;
- pedestrian pass door;
- deceleration on opening and closing;
- obstacle detection with dual technology;
- operation in event of power failure by means of optional rechargeable batteries (PS324);
- provision for connection of latest generation resistive sensitive edges.

Technical specifications

Code	TO7024
Electrical data	
Power supply (Vac 50 Hz)	-
Power supply (Vdc)	24
Absorption (A)	5
Power (W)	120
Built-in capacitor (µF)	-
Performance data	
Speed (m/s)	0.013
Force (N)	2700
Work cycle (cycles/hour)	41
Dimensional and general data	
Protection level (IP)	44
Working temp. (°C Min/Max)	-20 ÷ +50
Dimensions (mm)	1200x128x150 h
Weight (kg)	15

Installation diagram

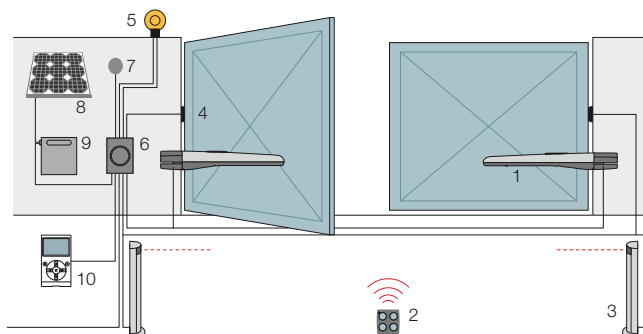

1. Toona 2. Transmitter 3. Photocells mounted on posts 4. Photocells 5. Flashing light 6. Control unit 7. Digital or key switches 8. SYP* solar panel 9. PSY24* battery box 10. O-View* multifunction display. *Optional connection to Solemyo and Opera systems.

Utilisation limits

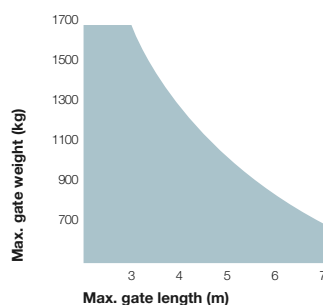

The shape, the height of the gate and the weather conditions can considerably reduce the values shown in the graph to the side.



For swing gates with leaves up to 3 m, also with large pillars.

Electromechanical gear motor, surface mounted, also in 24 Vdc version with magnetic encoder, with articulated arm.

Single model for right and left leaves. Two irreversible versions, with 230 Vac (HY7005) and 24 Vdc (HY7024) power supplies with magnetic encoder.

Fewer connections mean **quicker installation**.

Pre-wired, incorporated double limit-switch both during opening and closing (HY7005).

Easy to install: nothing welded to the gates.

Long-lasting: solid metal mechanics.

Compact: shockproof bodywork with no sharp corners.

Recommended control units: Mindy A3, A3F, A6, A6F, A60, A700F; for HY7024 Moonclever MC824H.

24 Vdc version with magnetic encoder. Perfect for intensive use, compatible with the control unit Moonclever MC824H, equipped with BlueBUS, and provision for operation with the systems Solemyo and Opera:

- simple programming, by means of a single key;
- self-learning of opening and closing limit positions;
- automatic fault diagnostics;
- programming of pause time;
- pedestrian pass door;
- deceleration on opening and closing;
- obstacle detection with dual technology;
- operation in event of power failure by means of optional rechargeable batteries (PS324);
- provision for connection of latest generation resistive sensitive edges.

Technical specifications

Code	HY7024	HY7005
Electrical data		
Power supply (Vac 50 Hz)	-	230
Power supply (Vdc)	24	-
Absorption (A)	5	1.2
Power (W)	120	250
Built-in capacitor (µF)	-	10
Performance data		
Speed (Rpm)	2	1.7
Torque (Nm)	250	400
Work cycle (%)	80	30
Dimensional and general data		
Protection level (IP)	43	
Working temp. (°C Min/Max)	-20 ÷ +50	
Dimensions (mm)	350x165x242 h	
Weight (kg)	13	

Installation diagram

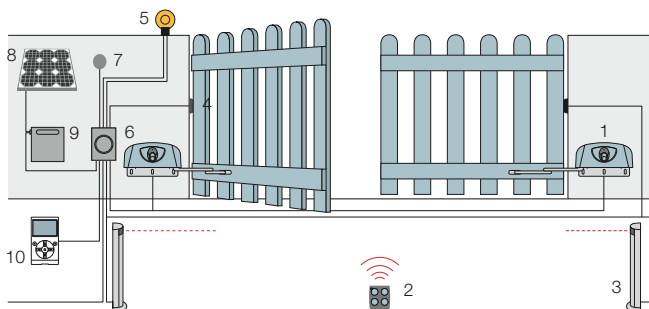

1. Hyppo 2. Transmitter 3. Photocells mounted on posts 4. Photocells 5. Flashing light 6. Control unit 7. Digital or key switches 8. SYP* solar panel 9. PSY24* battery box 10. O-View* multifunction display.
*Optional connection to Solemyo and Opera systems.

Utilisation limits

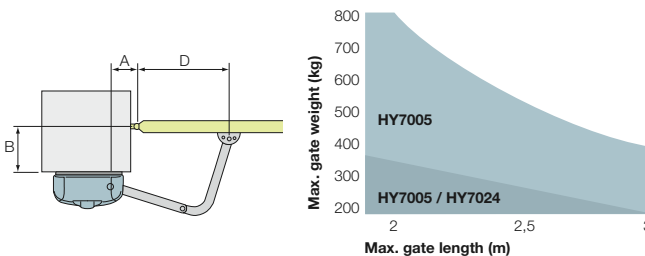

	Standard	HYA12
A max	150	400
B max	350	450
D max	450	800

N.B. The above values are valid if the motor is used with standard accessories. The shape, the height of the gate and the weather conditions can considerably reduce the values shown in the graph to the side. Use in windy areas 230 Vac models.

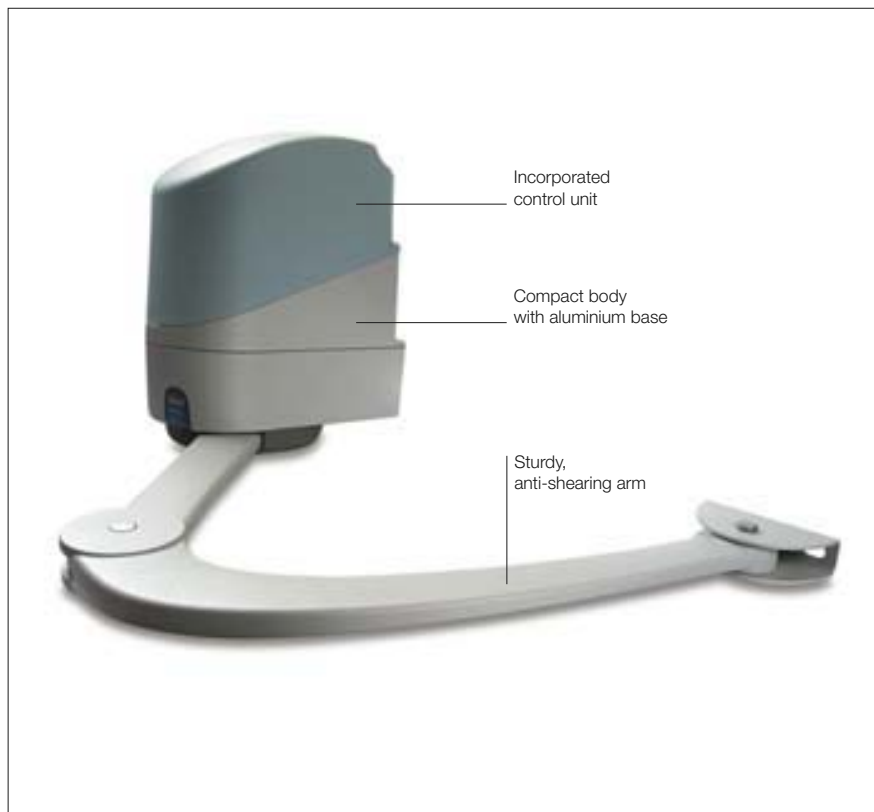

For swing gates with leaves max. 2 m, and those versions with large pillars and lightweight structures, ideal for one leaf pedestrian gates.

Electromechanical gear motor irreversible 24 Vdc with articulated arm, surface mounted.

Compatible for operation with Solemyo system.

Two irreversible 24 Vdc versions complete with limit switch on opening either without control unit (PP7224) or with incorporated control unit (PP7024).

User-friendly: release with personalised Nice key designed for cord-type release.

Sophisticated electronics: slowdown, obstacle detection system, can be linked to the 8.2 KOhm resistive sensitive edge.

Easy to install: no welding.

Compact: 167 mm in width, ideal for any kind of post.

Always ready for use: continues to work even during power failures using optional (PS124) batteries that fit inside the motor.

Powerful: thanks to the 180 Nm torque.

Small shockproof body with aluminium base.

Perfect for intensive use:

- easy programming by pressing a single button;
- clutch with anti-crush safety feature;
- automatic memorization of limit switches on opening and closing with self-learning function;
- programming of pause time;
- pedestrian pass door;
- deceleration on opening and closing.

Technical specifications

Code	PP7024	PP7224*
Electrical data		
Power supply (Vac 50 Hz)	230	-
Power supply (Vdc)	-	24
Absorption (A)	1	3
Power (W)	75	
Built-in capacitor (µF)	-	
Performance data		
Speed (Rpm)	1.68	
Torque (Nm)	180	
Work cycle (cycles/hour)	80	
Dimensional and general data		
Protection level (IP)	44	
Working temp. (°C Min/Max)	-20 ÷ +50	
Dimensions (mm)	167x254x315 h	
Weight (kg)	10	

* Version without control unit.

Installation diagram

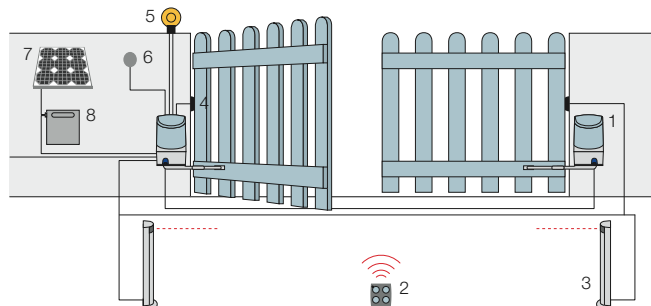

1. Pop 2. Transmitter 3. Photocells mounted on posts 4. Photocells 5. Flashing light 6. Digital or key switches 7. SYP* solar panel 8. PSY24* battery box.
*Optional connection to Solemyo system.

Utilisation limits

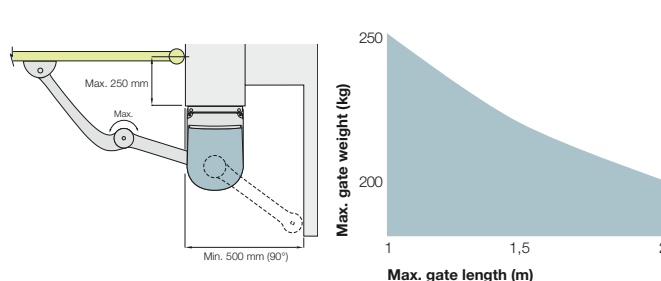

The shape, the height of the gate and the weather conditions can considerably reduce the values shown in the graph to the side.

Nice Wingo4024Kit - 5024Kit



For swing gates with leaves up to 2 m (Wingo4024Kit) and up to 3,5 m (Wingo5024Kit), mounted externally.

24 Vdc electromechanical gearmotor.

Versions designed with provision for solar power system Solemyo, thus enabling installation also in distant locations, far from electrical mains, with no need for connections or excavation work, in total harmony with the environment.

WG4024



User-friendly release with personalised Nice key or standard lock (optional)

WG5024

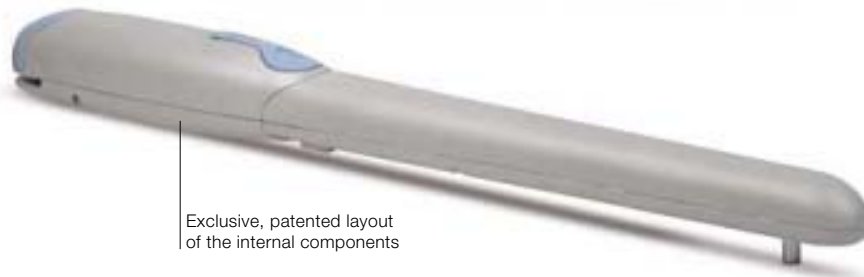

Exclusive, patented layout of the internal components

Gear motor characteristics:

- **reliable and silent:** thanks to the patented layout of the internal components and less moving parts;
- **easy to install:** after the gear motor has been assembled, all electrical connections are made from above;
- **user-friendly release** with personalised Nice key or standard lock (optional);
- pre-assembled, **travel stops** PLA13 in opening.

New Moonclever control unit (MC424):

- easy programming by pressing a single button;
- clutch with anti-crush safety feature;
- automatic memorization of limit switches in opening and closing with self-learning function;
- pause time programming; partial opening; slowdown during opening and closing.

Sophisticated electronics: slowdown, obstacle detection system, can be linked to the 8,2 KOhm resistive sensitive edge.

No blackout: continues to work even during power failures using optional (PS124) batteries that fit inside the control unit.

The kit contains:



WG4024 2 surface-mounted electromechanical gear motors, with Nice key release (Wingo4024Kit).

WG5024 2 surface-mounted electromechanical gear motors, with Nice key release (Wingo5024Kit).

Common accessories in the 2 kits:

FLO2R-S 1 transmitter 433.92 MHz, 2 channels. **MC424** 1 control unit with plug-in receiver SMX1.

MOF 1 pair of photocells for outdoor installation. **MOSE** 1 key selector switch for outdoor installation.

ML24 1 flashing light. **PLA13** 2 travel stops for opening manoeuvres. **TS** 1 signboard.

N.B. The content of the package may vary; consult the retailer.

Technical specifications

Code	Description	Pz/pallet
WINGO4024KCE	Kit for swing gates with leaves up to 2 m, surface mounted	12
WINGO5024KCE	Kit for swing gates with leaves up to 3,5 m, surface mounted	12

Motor code	WG4024	WG5024
Electrical specifications		
Power (Vdc)		24
Current absorbed (line) (A)		3,5
Power absorbed (W)		85
Built-in capacitor (µF)		-
Performance data		
Speed (m/s)	0,018	0,016
Torque (N)		1500
Work cycle (cycle/hour)		30
Dimensions and general data		
Working temp. (C°)		-20 ÷ +50
Protection level (IP)		44
Dimensions (mm)	98x95x770	98x95x920
Weight (kg)	17	18

For updated and complete information, consult the product technical manual.

Technical layout drawing and application limits

WG4024

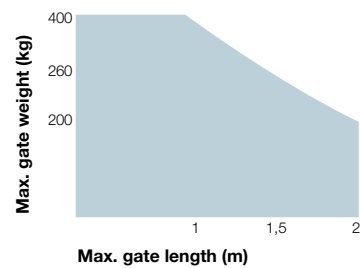
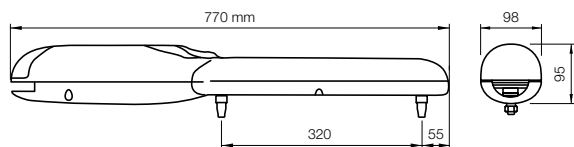

WG5024

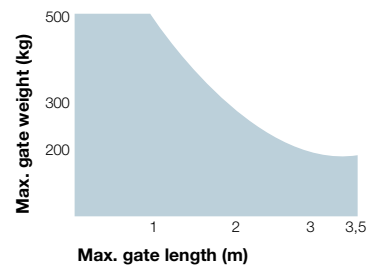
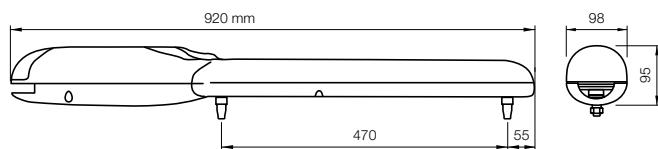

Installation diagram

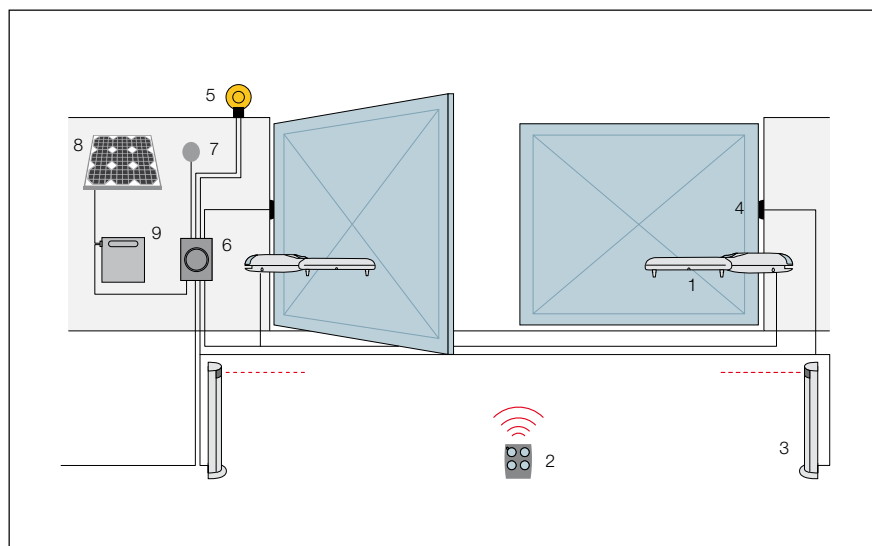

- 1. Wingo 2. Transmitter 3. Photocells mounted on posts
- 4. Photocells 5. Flashing light 6. Moonclever control unit
- 7. Digital or key switches 8. SYP* solar panel
- 9. PSY24* battery box

*Optional connection to Solemyo

MhouseKit WG20

The powerful solution featuring a simple and linear design for swing gates



Kit for the automation of a residential two-leaf gate, each leaf measuring up to 4m in width and weighing up to 400kg for leaf

Easy installation with the Mhouse

ECSBus system: only two wires are required for polarity free connection of the main system components. The colour-coded terminals, each of which identifies a set, enable quick, error-proof connections. The aerial is integrated in the flashing light for greater protection. No welding is required for system installation. Adjustable multi-position mounting brackets

Noiseless and reliable: body made of painted die-cast aluminium; mechanical parts made of metal

Convenience: operation during power failures guaranteed by the PR1 buffer batteries (optional) which are housed inside the control unit, and which can be connected using a convenient plug-in connector. Mhouse key-operated release device enables you to open and close the gate manually. Opening and closing mechanical stops

Maximum safety ensured by the low voltage connections and the automatic obstacle detection feature

External modular control unit: electronic board with integrated receiver and removable box to facilitate maintenance; transformer; compartment for PR1 buffer batteries (optional)

Control unit function selection:

2 speeds: slow for heavy gates, slow or fast for lighter gates

Automatic timed closing of the gate after each opening manoeuvre, or closing manoeuvre commanded only by the transmitter or key-operated selector switch.

New transmitters can also be fitted (those included in the kit are pre-memorized)

Transmitter function selection:

Partial opening of gate, to restrict passage to pedestrians and bicycles

Adjustment of pause time before the automatic closing starts

Adjustment of sensitivity to obstacles detected along the path of the gate before the movement is reversed

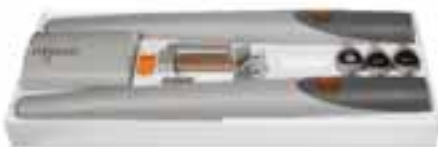

mhouse
4

Mhouse
Via Pezza Alta 13
31046 Oderzo TV Italia
Tel. +39 0422 202 109
Fax +39 0422 853 585
info@mhouse.biz
www.mhouse.biz

Installation

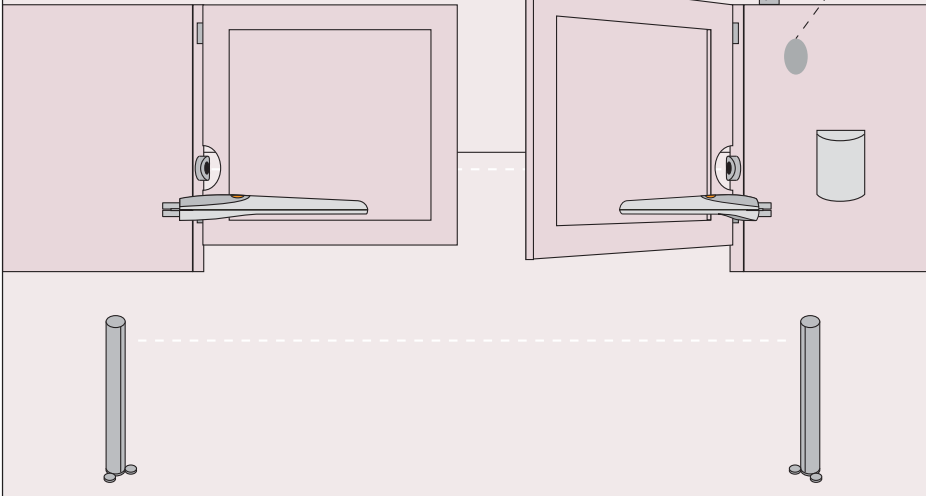

1 Mount the brackets on the gate, observing the dimensions shown in the instructions

2 Secure the motors to the gate

3 Install and connect all the system elements

4 Connect the wires with the terminals to the control unit and start the automatic programming function

5 The system is ready to receive your commands!



Connections

The gauges of the required power cables are specified on the technical literature (the length varies according to the installation layout)

Operating limits

Max weight of leaf (kg)	400
Max length of leaf (m)	4
Max leaf opening angle	130°
Max no. of manoeuvres/day	50*
Operating temperature (°C)	-20 ÷ +50

*opening + closing

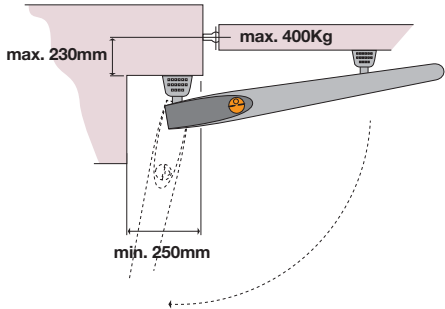

Each Kit WG20 contains:

2 WG10 Electromechanical worm gear motor with three Mhouse release keys and adjustable mounting brackets included.



2 TX4 433.92MHz 4 buttons variable code transmitters



1 PH1 Pair of wall-mounted autosynchronized photocells



1 KS1 Two-position (open/stop) key-operated selector switch with pair of metal keys



1 FL1 Adjustable flashing light with incorporated aerial



1 CL2 External control unit for control of two WG10 series electromechanical gear motors with integrated 433.92MHz variable code receiver.



Accessories:

PT50 Two posts of 485mm high complete with a pair of premounted photocells
PT100 Two posts of 945mm high complete with two pairs of premounted photocells

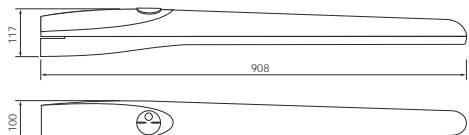

PR1 24V buffer battery for emergency power supply

